

RPG-MWSC-160

Radiometer physics GmbH (RPG) offers the only commercially available microwave scintillometer RPG-MWSC-160. It is designed for the combined operation with an optical Large Aperture Scintillometer (LAS) to simultaneously observe sensible and latent heat fluxes. RPG has now introduced the second instrument generation (G2). The RPG-MWSC-160-G2 includes an automatic gain control on the receiving end. This feature is particularly beneficial for long-term deployments, because the mean received signal is automatically adjusted to seasonal variations.



Applications

Simultaneous observations of **sensible heat flux H** and evapotranspiration (**latent heat flux $L_v E$**) are significant for:

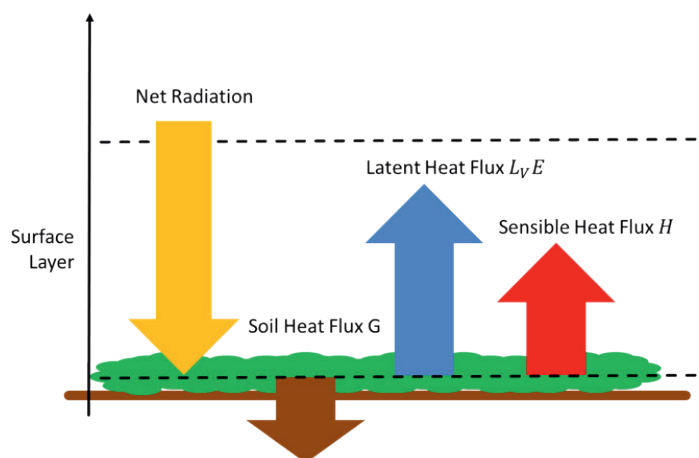
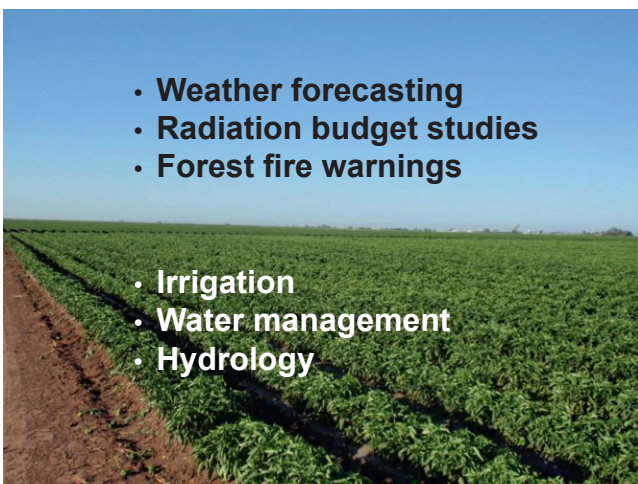

Concept of Scintillometry

- Transmit/receive system
 - Transmitter emits a constant signal
 - Receiver observes fluctuations
- Information content: Turbulence modulates refractive index of air \Rightarrow intensity fluctuations
- Combination of microwave (RPG-MWSC-160) and infrared (LAS) frequencies allows for simultaneous determination of sensible and latent heat fluxes.

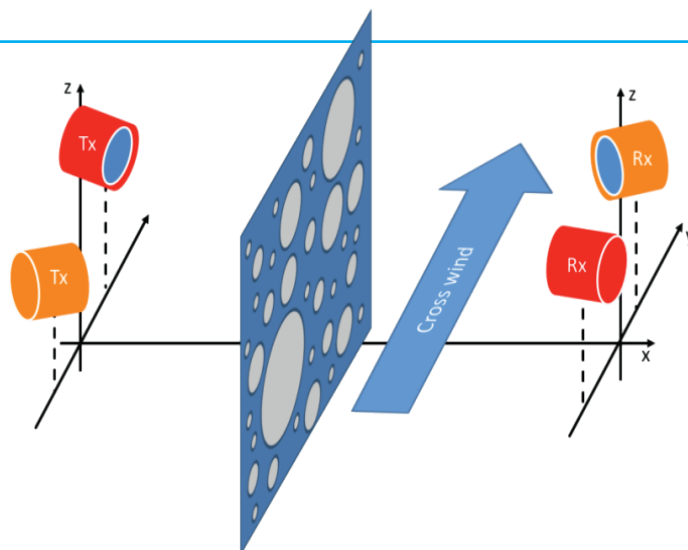

Setup of a combined **MWS** and **LAS** system with crossing signal beams. The turbulence field is shifted through the beams by the mean wind across the measurement path.

Design

The RPG-MWSC-160 prototype was developed by RPG and Wageningen University (The Netherlands) within the OMS (Optical and Microwave Scintillation) project. The RPG-MWSC-160 uses hardware developments from RPG space projects.

- High frequency (160.8 GHz) for good co-spectrum with LAS
- Large aperture (300 mm) provides small beam width
- Tuneable power level (0-25 mW) allows lengths between 500 m and 10 km
- Low weight (~10 kg) and power consumption (~20 W)

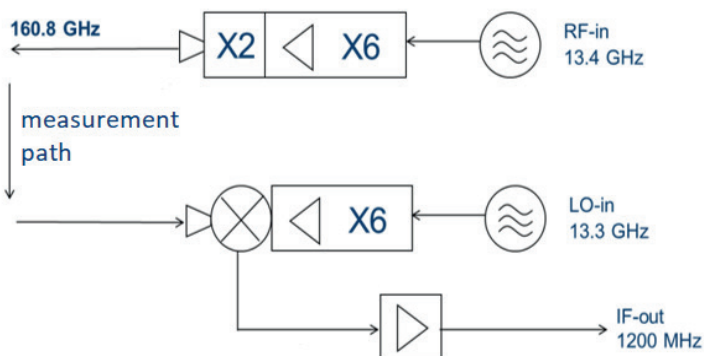

Operating Software

The RPG-MWSC-160 comes with a comprehensive operating software package [2]. The software synchronously digitizes the microwave and optical raw signals. Complete data processing from raw signals to heat fluxes is performed **online**. All data products are continuously displayed on the screen and automatically stored in files.

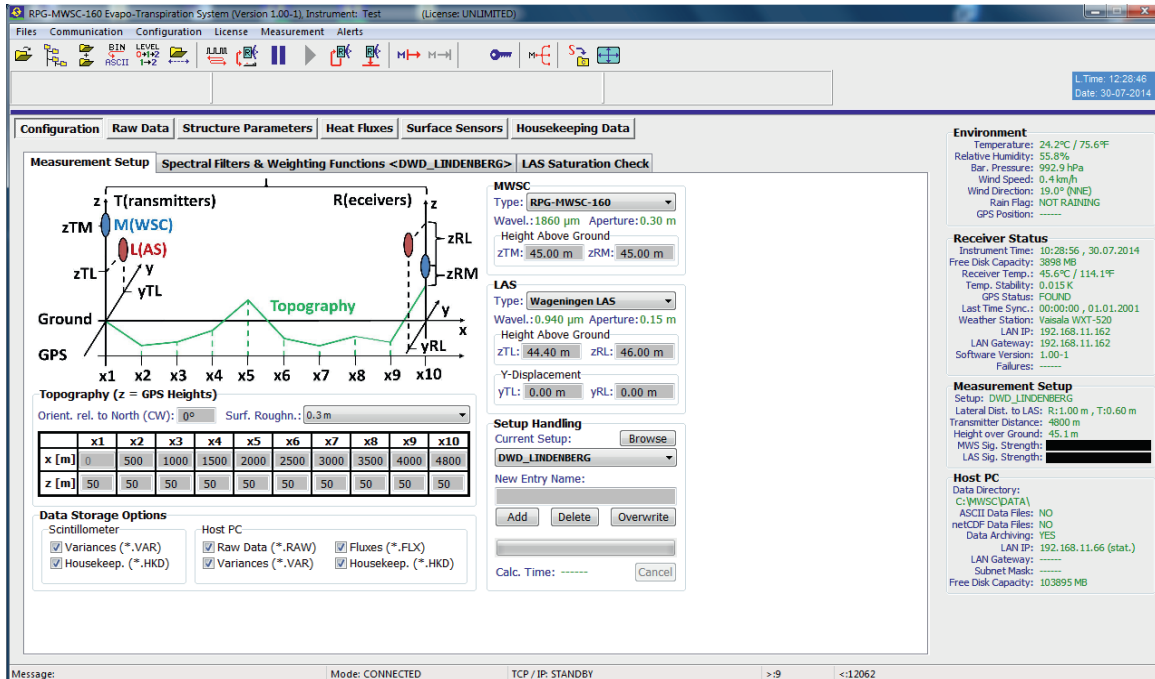

User interface for setup of a combined optical/microwave system.

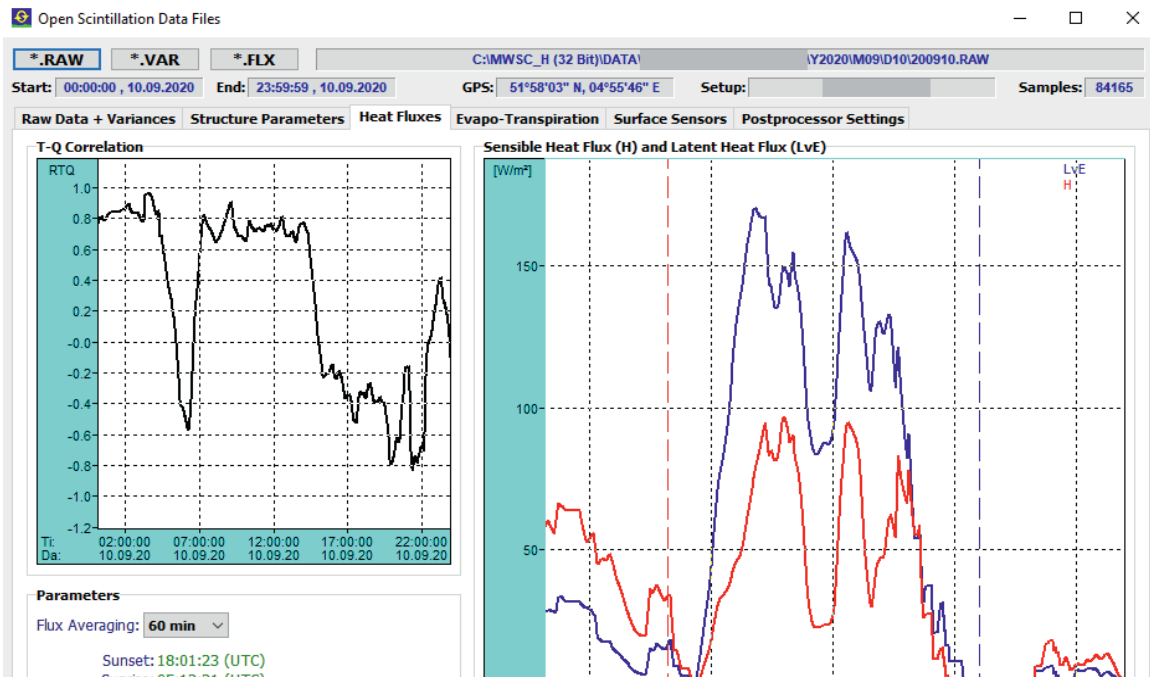

Left: Temperature-humidity correlation coefficient RTQ [1]. Right: Daily time series of sensible (red) and latent (blue) heat flux estimates.

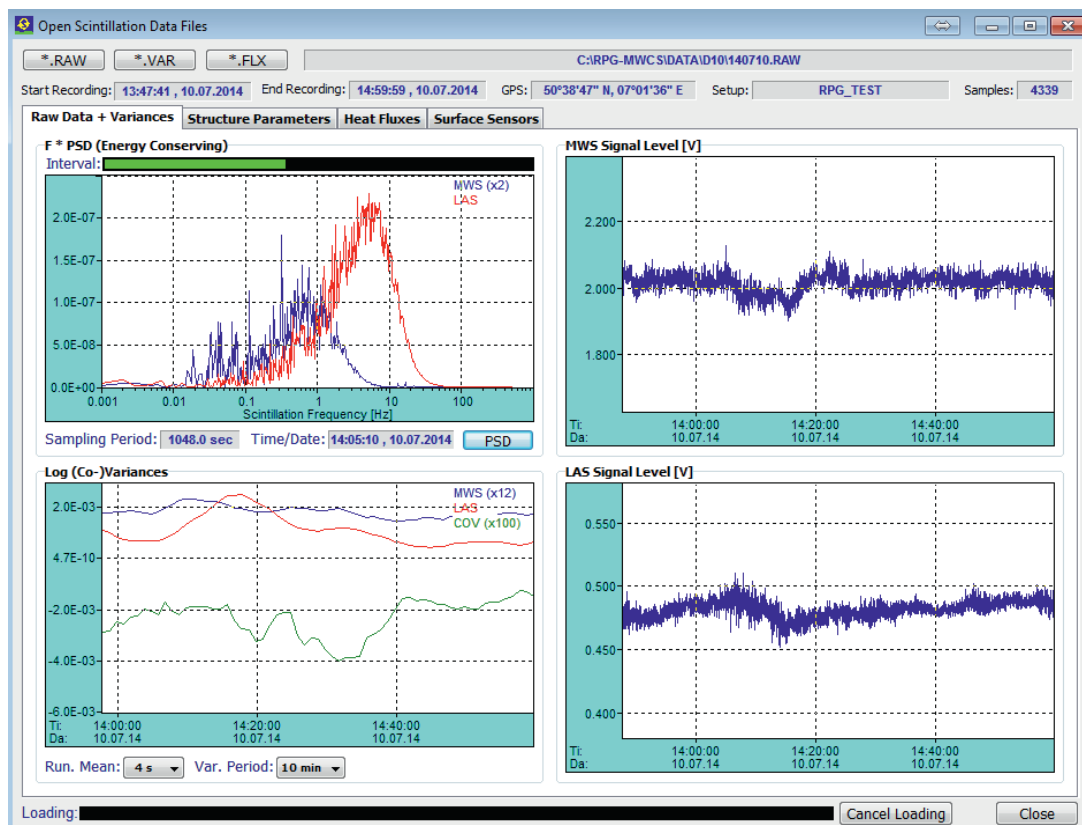

Power spectra, raw signals and variances are continuously displayed.

Data Processing

- Data Processing following Lüdi et al. [1] (see instrument manual [2] for details):
 - Calculate signal MWS and LAS variances and covariance between the signals.
 - Triplet of variances \Rightarrow structure parameters of refractive index (C_n^2).
 - Read surface sensors from integrated weather station.
 - Apply Monin-Obukhov Similarity Theory (MOST) \Rightarrow heat fluxes H and $L_V E$.
 - Derive flux signs from correlation coefficient R_{TQ} .

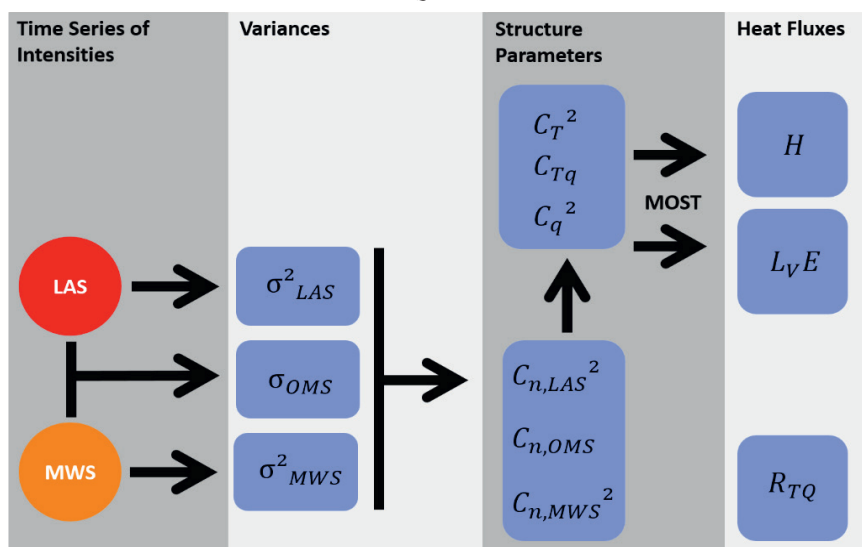

Field Observations Examples

During several field campaigns the RPG-MWSC-160 was successfully operated in combination with different LAS systems. A large range of applications was covered: observations were for example taken across homogeneous crop fields, over heterogeneous landscapes, above forest treetops of a forest, in deserts, and even in urban environments. The path lengths varied between a few hundred meters and several kilometers.

Altiplano, Chile

The RPG-MWSC-160 was operated in combination with a LAS system on the Andean Plateau to derive the local water balance from observed sensible and latent heat fluxes.

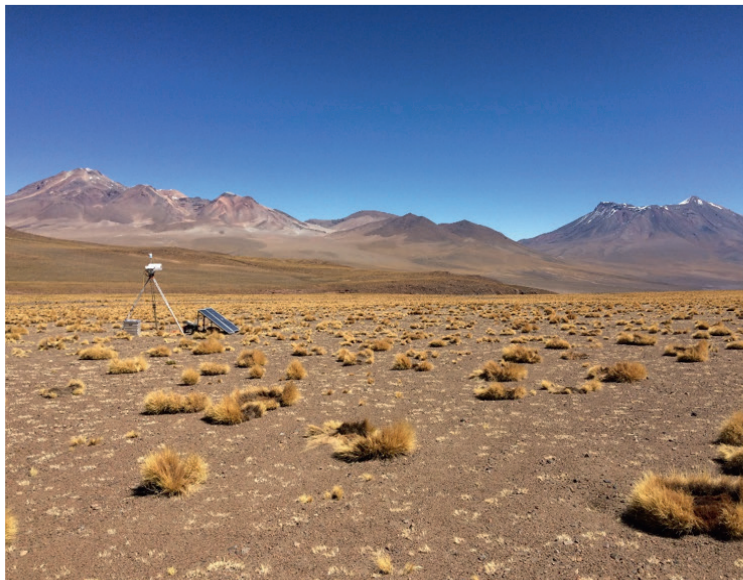
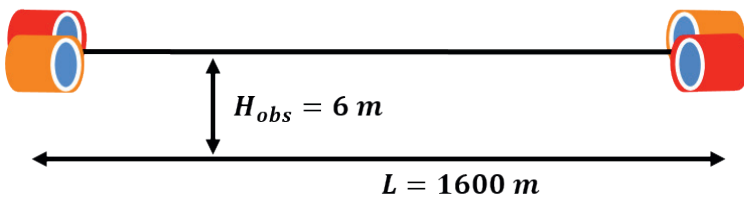

Altiplano, Chile - courtesy of Prof. Francisco Suárez Poch



Lindenberg, Germany

The RPG-MWSC-160 prototype was tested in mid-latitude continental climate. It was operated in combination with two LAS systems over a long signal path between two measurement towers. The setup is characterized by an inhomogeneous landscape with patches of woodland, lakes and crop fields. Since 2015, an RPG-MWSC-160 is continuously operated on the same path.

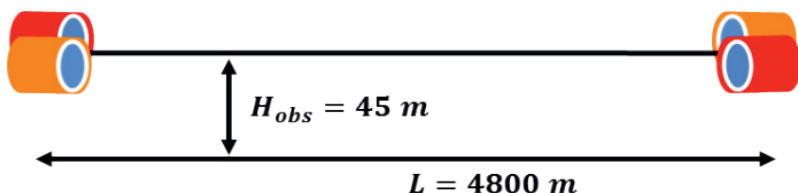

Lindenberg, Germany

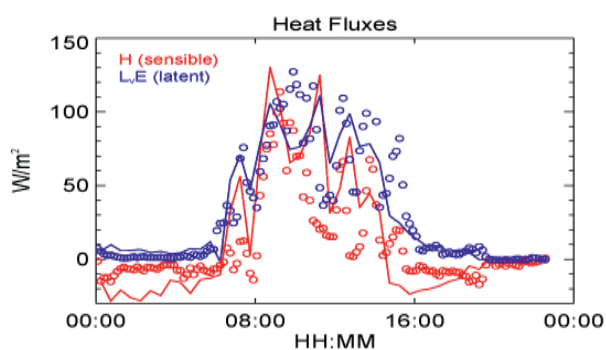
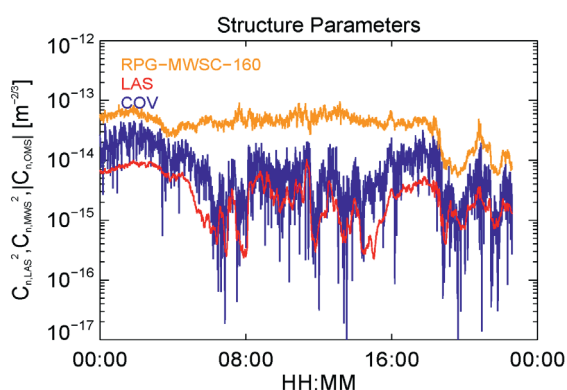

Lindenberg, Germany: Measurement time series for a long path over heterogeneous landscape (September 8, 2013, Germany).

Left: refractive index structure parameters for **RPG-MWSC-160**, optical **LAS**, and for the signal covariance (**COV**) of both instruments (combined optical / microwave method, Lüdi et al. [1]).

Right: estimates of path integrated **sensible heat flux H** and **latent heat flux L, E** . Circles give measurements from an Eddy Covariance station (EC).

Amsterdam, Netherlands

The scintillometer setup is part of a network of meteorological measurements in the city funded by the “Amsterdam Institute for Advanced Metropolitan Solutions” (www.ams-institute.org). The aim of the project is to better understand the local (down to street level) weather in the city and thereby also be able to make better local weather forecasts. Models that can predict the weather on such a small spatial scale are under development and need to be validated with measurements, including those from the scintillometer system. In addition, the scintillometer plays an important role in the (ground)water management of the city because of its ability to determine the evapotranspiration over the entire city center in a single integrated measurement.

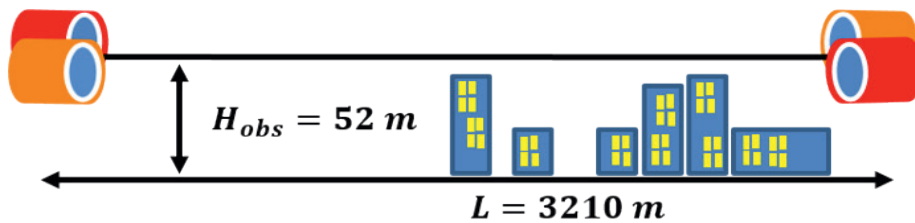

Amsterdam, Netherlands - courtesy of Oscar Hartogensis



Specifications

Parameter	Specification
Frequency	160.8 GHz ($\lambda=1.86$ mm)
Radiated power	tuneable from 0-25 mW (50 dB attenuator)
Antenna type	Cassegrain with 300 mm aperture
Antenna gain	52 dB
Beam Width	0.45° HPBW
Temperature stability	< 0.03 K (two-stage control)
Power supply	10.8 - 13.2 V DC (230 V AC input power supplies available as an option)
Power consumption	max. 60 W (per unit), 20 W typical (receiver), 15 W typical (transmitter)
Output Data	Level 0 <ul style="list-style-type: none">• 1 kHz digital raw data for RPG-MWSC-160 and LAS• housekeeping data.
	Level 1 (co)variances of the combined optical/microwave system.
	Level 2 <ul style="list-style-type: none">• structure parameters C_n^2• sensible and latent heat fluxes H, L, E
Type of installation	Line of sight Tx/Rx system (transmit/receive)
Baseline length	500 m to 10 km

References

[1] A. Lüdi, F. Beyrich, and C. Mätzler, “Determination of the Turbulent Temperature–Humidity Correlation from Scintillometric Measurements”, *Bound.-Layer Meteorol.*, vol. 117, no. 3, pp. 525–550, Dec. 2005.

[2] RPG-MWSC-160-Instrument Manual, “Installation, Operation and Software Guide”, RPG Radiometer Physics GmbH (provided via email upon request)